

# YAMAHA

# EH Series

## MULTI-PURPOSE ENGINES



**EH72**



**EH64**



**EH65**



**US EPA Phase III**

**CARB Tier III**

**EC Stage II**

**LEMA Phase III**

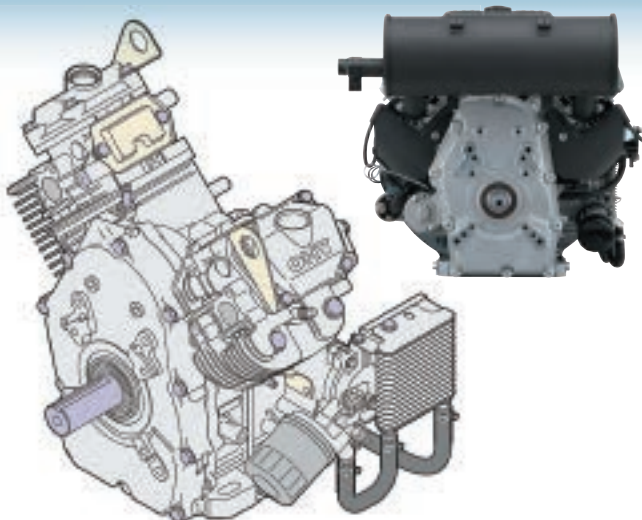

- **Powerful V-twin OHV**
- **Carburetor for easy maintenance**
- **Emission regulation applied**
- **Full pressure & filtrated lubrication**
- **Oil cooler for EH72**
- **Cast iron cylinder liner**
- **Twin ball bearing supported crankshaft**
- **12V15A high wattage alternator**
- **Large capacity dual filtration air filter**

## SPECIFICATIONS

Model name	EH64	EH65	EH72
Type	Air-cooled, OHV, V-twin, Horizontal shaft	Air-cooled, OHV, V-twin, Horizontal shaft	Air-cooled, OHV, V-twin, Horizontal shaft
Bore × Stroke	80 × 65 mm	80 × 65 mm	84 × 65 mm
Displacement	653 cm <sup>3</sup>	653 cm <sup>3</sup>	720 cm <sup>3</sup>
Maximum output (Net)	14.6 kW @3600 r/min	15.0 kW @3600 r/min	17.2 kW @3600 r/min
Rated output (Net)	11.9 kW @3600 r/min	12.7 kW @3600 r/min	14.2 kW @3600 r/min
Maximum torque (Net)	44.3 N·m @2200 r/min	45.6 N·m @2500 r/min	51.0 N·m @2800 r/min
PTO Shaft Rotation	Counterclockwise (from PTO shaft side)	Counterclockwise (from PTO shaft side)	Counterclockwise (from PTO shaft side)
Fuel	Unleaded gasoline	Unleaded gasoline	Unleaded gasoline
Oil Capacity	1.55 L (including oil filter)	1.55 L (including oil filter)	1.55 L (including oil filter)
Ignition System	Twin TCI	Twin TCI	Twin TCI
Spark Plug	NGK BPR5ES	NGK BPR5ES	NGK BPR5ES
Starter	Electric starter	Electric starter	Electric starter
Lubrication System	Full filtered pressure lube	Full filtered pressure lube	Full filtered pressure lube
Charging Capacity	12V - 15A	12V - 15A	12V - 15A
Dry Weight	49.5 kg	49.5 kg	51.5 kg
Dimension (L × W × H)	463 × 499 × 476 mm	463 × 499 × 476 mm	463 × 499 × 476 mm

## PERFORMANCE CURVE

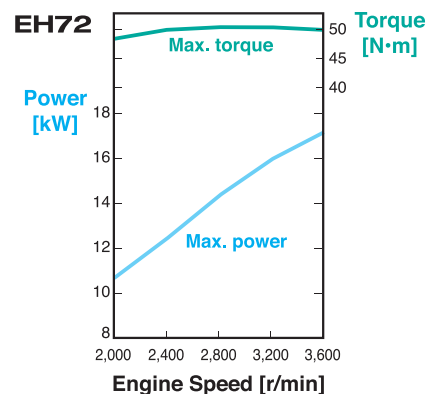
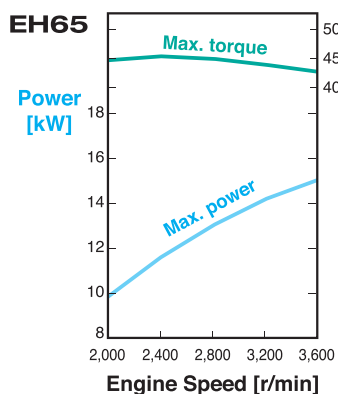
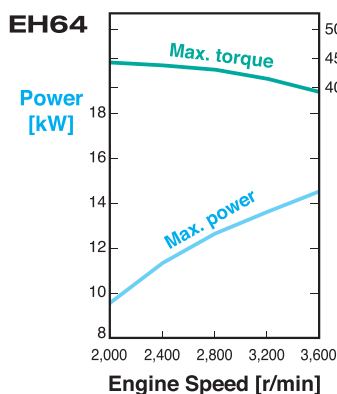

## DIMENSIONS

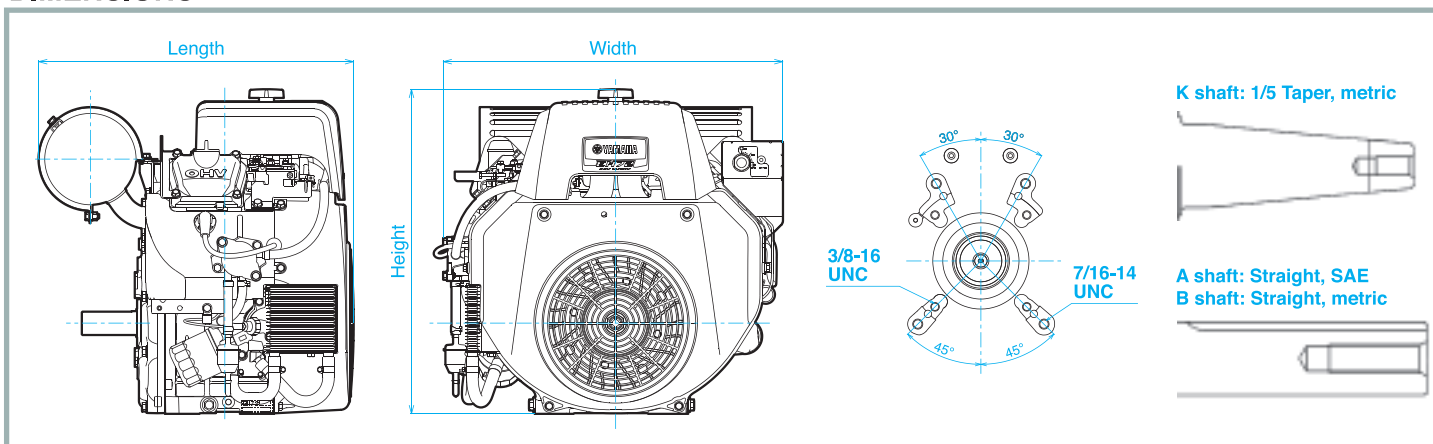

- Specifications are subject to change without notice.
- Due to factors such as specification changes, actual products may be different in some aspects from those pictured or described here.
- Batteries are not included on models with electric starters.
- Be sure to read the owner's manual thoroughly before using to ensure proper use.



**Virtute Maris**  
Dystrybutor w Polsce

**VIRTUTE MARIS Sp. z o.o.**  
ul. Twarda 18, 00-105 Warszawa  
Mobile + 48 600 666 346  
Tel + 48 22 245 09 17  
NIP: 951 247 41 83  
REGON: 381912349  
[info@silniki-benzynowe.pl](mailto:info@silniki-benzynowe.pl)  
[www.silniki-benzynowe.pl](http://www.silniki-benzynowe.pl)



YAMAHA MOTOR POWERED PRODUCTS CO., LTD.  
200-1 SAKAGAWA KAKEGAWA SHIZUOKA JAPAN

Printed in Japan  
339389 - 1903OGD0.2-EN-a1