

MA Series

MULTI-PURPOSE ENGINES



MA175

MA190

- **Delivers High Power and Excellent Fuel Efficiency through Advanced Engine Technologies**
- **Offers an Optimized Layout for High Reliability, Durability, Usability and Mountability**



US EPA Phase III
CARB Tier III

EC Stage II
China II

Note: Equipments such as PTO shaft, fuel filler cap, muffler protector etc. are vary among the requests.

Clip-on air cleaner

Clip-on air cleaner allows quick maintenance without any tools.

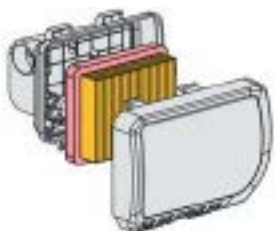

Low-profile OHC

Low profile OHC system is exclusively designed for compact as OHV head.



HEMI-head

HEMI-Head and V valves layout produces "high Power & Economy".

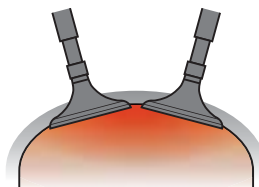

HEMI head

Long neck gauge

Extended long neck oil gauge ease of sure oil level checking & filling oil.



Quick-lock cap

Just twist 90 degrees for smooth & sure releasing or locking.

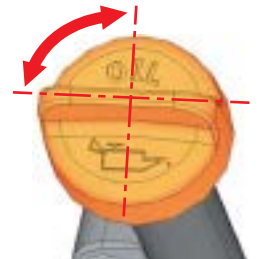

PERFORMANCE CURVE

MA175 (SAE-J1349)

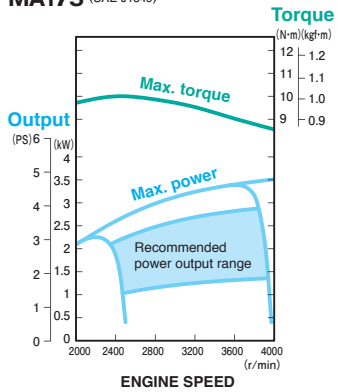

MA190 (SAE-J1349)

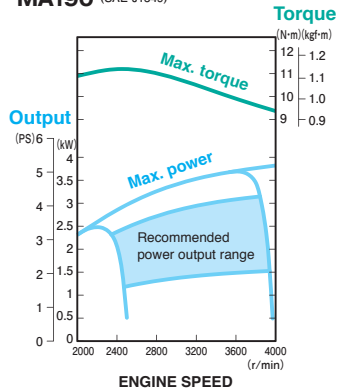

SPECIFICATIONS

Model name	MA175	MA190
Engine Type	Air Cooled Hemi-head OHC, Vertical Shaft	
Bore × Stroke	68 × 48 mm	68 × 52 mm
Displacement	174 cm ³	189 cm ³
Compression Ratio	8.5	
Max Power (Net)	3.4 kW (4.5 ps) @3600 r/min	3.7 kW (5 ps) @3600 r/min
Rated Power (Net)	2.8 kW (3.75 ps) @3400 r/min	3.4 kW (4.5 ps) @3400 r/min
Max Torque (Net)	10.0 N·m (1.0 kgf·m) @2500 r/min	11.2 N·m (1.1 kgf·m) @2500 r/min
Fuel	Automobile gasoline	
Fuel Tank Capacity	1.2 L	
Ignition System	Transistorised	
Spark Plug	Torch E7RTC / NGK BPR7HS or equivalent	
Lubrication System	Splash	
Oil pan Capacity	0.5 L	0.6 L
Dry Weight	12.5 kg	14.0 kg
Dimensions L×W×H	417 × 357 × 270 mm	424 × 351 × 297 mm

DIMENSIONS (Unit: mm)

MA175

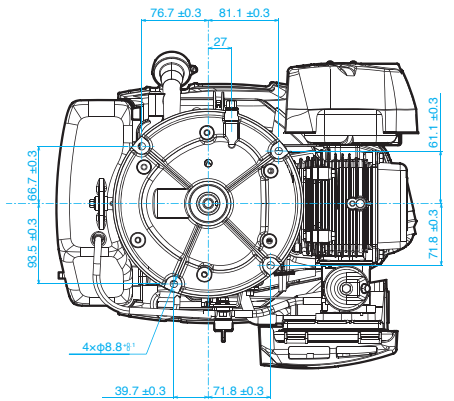
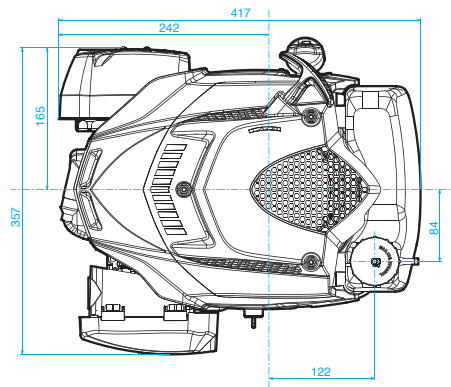
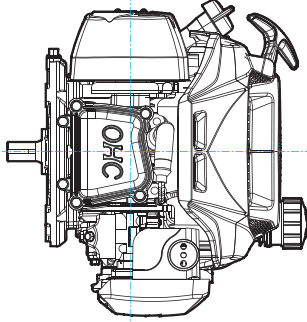

MA190

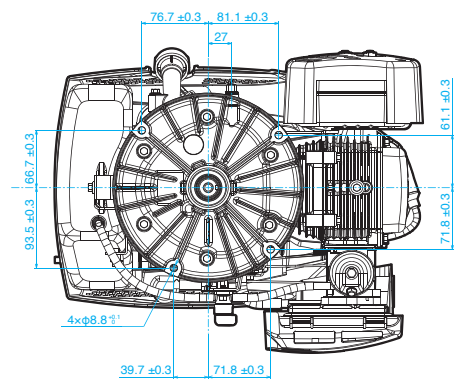
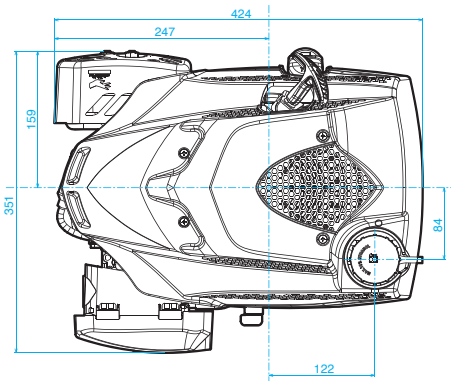
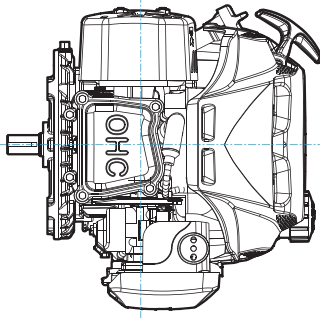

Mounting Face Dimensions

MA175

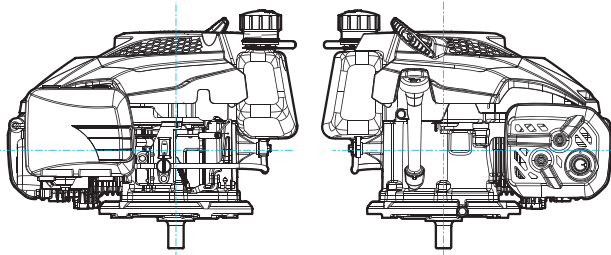

P.T.O. Shaft Dimensions

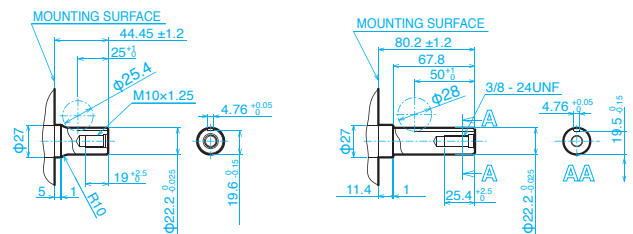

Note: Inquire the availability for the shaft variations



Virtute Maris
Dystrybutor w Polsce

VIRTUTE MARIS Sp. z o.o.
ul. Twarda 18, 00-105 Warszawa
Mobile + 48 600 666 346
Tel + 48 22 245 09 17
NIP: 951 247 41 83
REGON: 381912349
info@silniki-benzynowe.pl
www.silniki-benzynowe.pl

- Please read the owner's manual carefully before operating, and be sure to operate the machine properly.
- Regularly inspect the engine and perform maintenance when necessary. Keep the machine in good operating condition at all times.
- Turn the engine off and keep away from open flames whenever refueling the machine. Also, immediately wipe up any spilled fuel.
- Operate the engine only in a well-ventilated area.
- Do not touch the engine and muffler during operation or shortly after stopping.
- Specifications are subject to change without notice.



YAMAHA MOTOR POWERED PRODUCTS CO., LTD.
200-1 SAKAGAWA KAKEGAWA SHIZUOKA JAPAN

Printed in Japan
[339348]-1707OGD3-a1

